

---

## Power Steering Pump to Steering Gear Pressure Line — 5.4L

### Special Tool(s)

 ST1444-A	Installer Set, Teflon® Seal 211-D027 (D90P-3517-A) or equivalent
---	--

### Material

Item	Specification
MERCON® V Automatic Transmission Fluid XT-5-QM (or XT-5-QMC) (US); CXT-5- LM12 (Canada)	MERCON® V

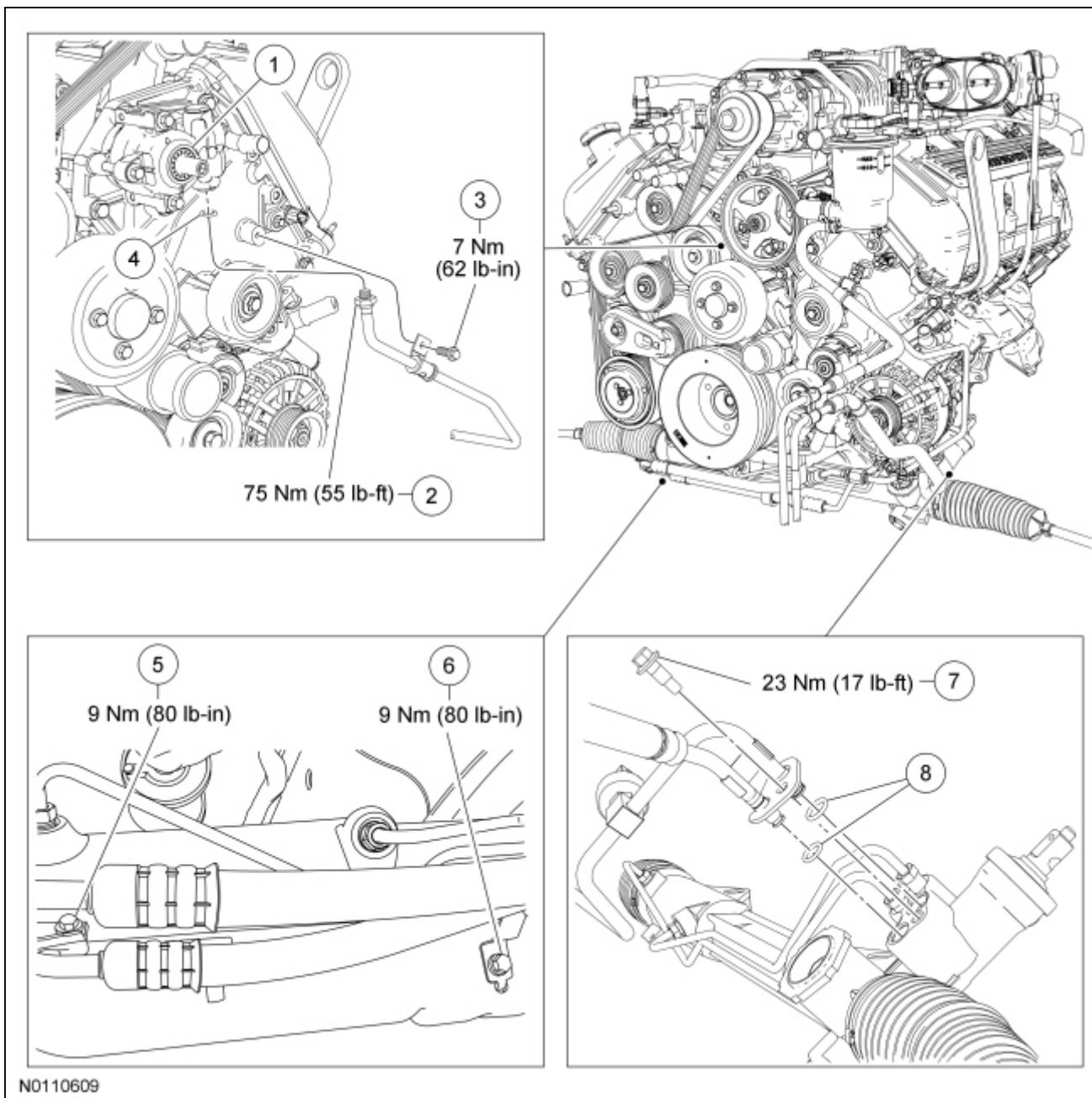

N0110609

Item	Part Number	Description
1	3A674	Power steering pump
2	—	Pressure line-to-pump fitting (part of 3A719)
3	W505255	Pressure line bracket-to-engine bolt
4	388898	Teflon® seal
5	W505255	Pressure line bracket-to-steering gear bolt
6	W505255	Pressure line bracket-to-crossmember bolt
7	W707622	Power steering line clamp plate bolt
8	3F886-AA 3F886-BA	O-ring seals (2 required)

## Removal and Installation

**NOTICE:** When repairing the power steering system, care should be taken to prevent the entry of foreign material or failure of the power steering components may result.

1. With the vehicle in NEUTRAL position it on a hoist. For additional information, refer to [Section 100-02](#).
2. Remove the power steering pump pulley. For additional information, refer to [Power Steering Pump Pulley](#)

— 4.6L, 5.4L in this section.

3. **NOTE:** A new Teflon® seal must be installed.

Disconnect the pressure line-to-pump fitting.

- Discard the Teflon® seal.
- To install, tighten to 75 Nm (55 lb-ft).

4. Remove the pressure line bracket-to-engine bolt.
  - To install, tighten to 7 Nm (62 lb-in).
5. Remove the pressure line bracket-to-alternator stud nut.
  - To install, tighten to 7 Nm (62 lb-in).

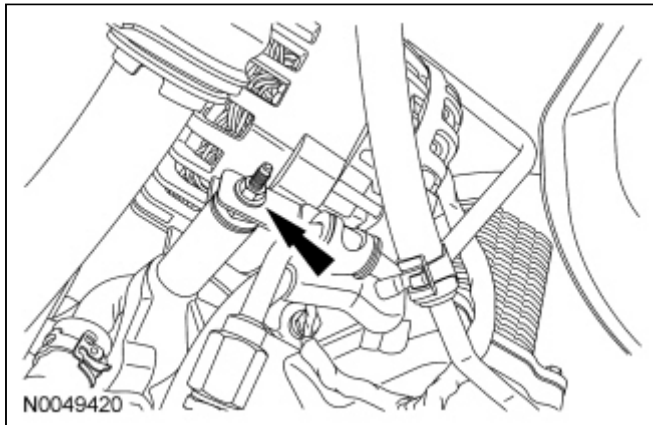

6. Remove the pressure line bracket-to-crossmember bolt.
  - To install, tighten to 9 Nm (80 lb-in).
7. Remove the pressure line bracket-to-steering gear bolt.
  - To install, tighten to 9 Nm (80 lb-in).
8. **NOTICE:** When installing the pressure and return lines to the steering gear, make sure the lines are fully seated into the steering gear prior to installing the clamp plate. Additionally, make sure that the clamp plate surfaces are free of foreign material. **DO NOT** exceed the specified torque when tightening the clamp plate. Leakage and/or premature failure of the power steering components may occur.

**NOTE:** New O-ring seals must be installed any time the lines are disconnected from the steering gear.

Remove the power steering line clamp plate bolt, rotate the clamp plate and remove the power steering pressure line.

- Discard the O-ring seal.
- To install, tighten to 23 Nm (17 lb-ft).

9. To install, reverse the removal procedure.
10. **NOTE:** A new Teflon® seal must be installed.

Using the Teflon® Seal Installer Set, install a new Teflon® seal to the pressure line-to-pump fitting.

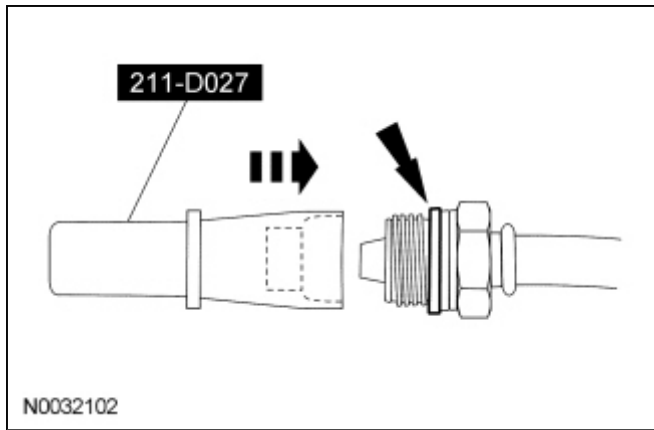

11. Fill the power steering system. For additional information, refer to [Section 211-00](#).
-